

LED Back Light

6.2" Passive Matrix Color LCD Module
KCG062HVLAK-G000

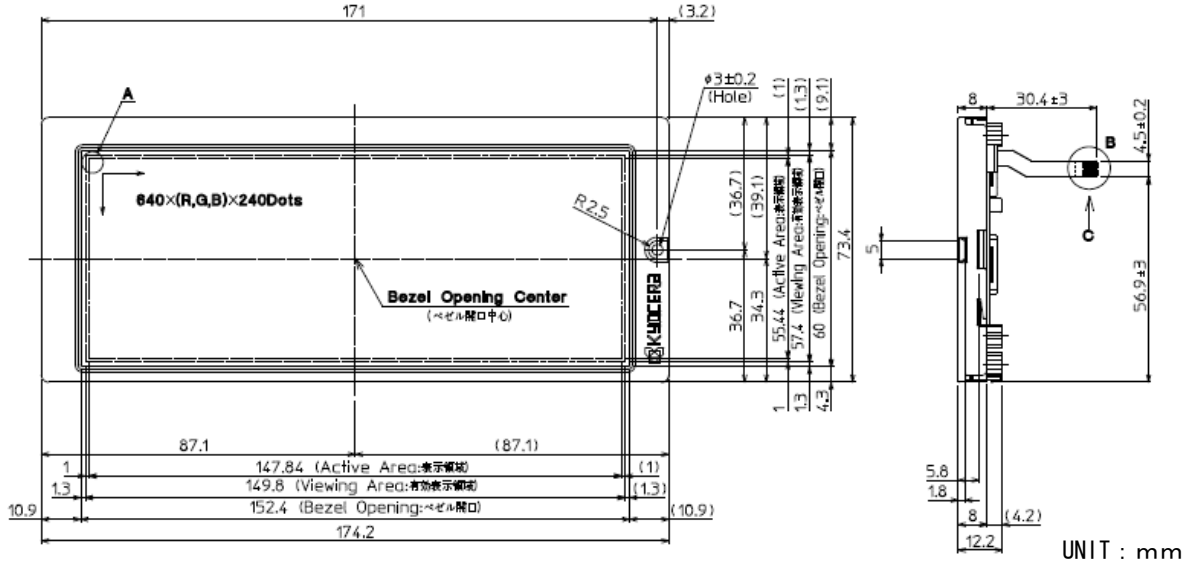

Features

- RoHS Compliant
- With LED B/L
- Symmetrical Design (Horizontal)
- Single Power Supply (With DC/DC Converter)
- Without Constant Current Circuit for LED B/L (Option)
- V Series Compatible Design
 - KHG062HV ... Color STN (Transflective)
 - THG062HV ... Color TFT (Transflective)

Applications

- Display for Industrial Machine
- Measuring Instrument, Chart Recorder, Scale
- POS, ATM, Bank Terminal
- Fish Finder, Musical Instrument, Sewing Machine
- Office Automation

Specification

ITEM	SPECIFICATION	UNIT
Dot Format	640 × (R, G, B) (W) × 240 (H)	dot
Dot Pitch	0.077 (W) × 0.231 (H)	mm
Outline Dimensions	174.2 (W) × 73.4 (H) × 12.2 (D)	mm
Mass	135	g
Contrast Ratio	30:1	—
Brightness	200 (IF=15mA/1Line)	cd/m ²
Response Time	490	ms
Viewing Angle (V/H)	50/100 (CR ≥ 2)	deg.
Power Consumption	182 (VDD=3.3V)	mW
	200 (VDD=5.0V) (LCD)	
Backlight	1.30 (Backlight)	W
Backlight	LED	—
Duty	1/240	—

ATTENTION : Specification subject to change without notice.
 Please check the latest version of the product specification.

KYOCERA CORPORATION
LCD Division

6 Takeda Tobadono-cho, Fushimi-ku, Kyoto 612-8501 Japan
 Phone: +81-75-604-3751 <http://www.kyocera.co.jp/lcd/>

- KYOCERA INDUSTRIAL CERAMICS CORPORATION (USA)
 Phone(Toll Free) : +1-800-826-0527 <http://www.kyocera.com/>
- KYOCERA FINECERAMICS GmbH (GERMANY)
 Phone : +49-711-939-3439 <http://www.kyocera.de/>
- KYOCERA FINECERAMICS S.A. (FRANCE)
 Phone : +33-1-45120239
- KYOCERA FINECERAMICS LTD. (UK)
 Phone : +44-1252-776000
- KYOCERA ASIA PACIFIC PTE. LTD. (SINGAPORE)
 Phone : +65-6271-0500
- KYOCERA ASIA PACIFIC PTE. LTD. TAIPEI BRANCH (TAIWAN)
 Phone : +886-2-2555-3609
- KYOCERA ASIA PACIFIC LTD. (HONG KONG)
 Phone : +852-2723-7183
- KYOCERA (Tianjin) SALES & TRADING CORPORATION (CHINA)
 Phone : +86-10-8528-8838 ext.103