

Temperature Compensated Crystal Oscillators (TCXO) Surface Mount Type TCXO (LSI Type) KT2520 Series



2.5×2.0mm



RoHS Compliant

Features

- Miniature SMD type (2.5×2.0×0.8mm)
- AFC function available
- Freq. temp. chrst. : $\pm 2.0 \times 10^{-6}/ -30$ to $+85^\circ\text{C}$
- 1.7 to 3.6V drive available
- Reflow compatible

Applications

- 3G (CDMA, W-CDMA, TD-SCDMA), GPRS, GSM, Wi-Fi, WiMAX

How to Order

KT2520F 26000 D C W 28 T xx
① ② ③ ④ ⑤ ⑥ ⑦ ⑧

① Series	⑥ Supply Voltage
② Output Frequency	28 2.8V 30 3.0V
③ Freq. Temp. Chrst.	⑦ Voltage Control Range
B $\pm 1.0 \times 10^{-6}$	T TCXO
C $\pm 1.5 \times 10^{-6}$	Other* VCTCXO
D $\pm 2.0 \times 10^{-6}$	* Customer Spec.
④ Lower Operating Temp.	⑧ Option Code
C -30°C	
E -20°C	
G -10°C	
⑤ Upper Operating Temp.	
W $+85^\circ\text{C}$	
V $+80^\circ\text{C}$	
U $+75^\circ\text{C}$	

Packaging (Tape & Reel 3000 pcs./ reel)

Specifications

Item	Symbol	Conditions	Min.	Max.	Units
Output Frequency Range	fo	Standard Frequency: 13, 19.2, 26, 38.4, 52	13	52	MHz
Frequency Tolerance	f _{tol}	vs Temperature	-2	+2	$\times 10^{-6}$
		vs Load	-0.1	+0.1	
		vs Voltage	-0.2	+0.2	
Frequency Aging	f _{age}	Per Year	-1	+1	$\times 10^{-6}$
Storage Temperature Range	T _{stg}		-40	+85	$^\circ\text{C}$
Operating Temperature Range	T _{use}		-30	+85	$^\circ\text{C}$
Voltage Control Range	f _{cont}	Positive	± 8	± 15	$\times 10^{-6}$
Supply Voltage	V _{CC}		1.7	3.6	V
Output Level	V _{pp}	Clipped Sine*, Load: 10k ohm // 10pF	0.8	—	Vp-p
Current Consumption	I _{CC}		—	2	mA
Harmonics	—		—	-5	dBc

* : A DC-cut capacitor is not embedded in this crystal oscillator. Connect a DC-cut capacitor ($\geq 1\text{nF}$) to the line-out terminal of the oscillator.

Dimensions

(Unit: mm)

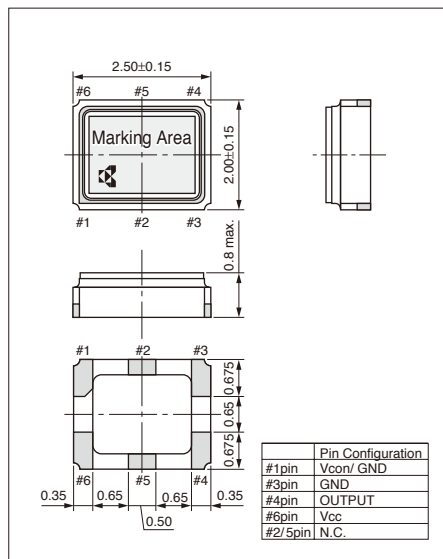

Test Circuit

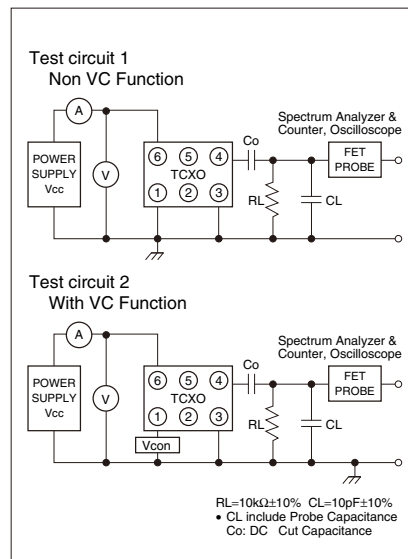

Recommended Land Pattern

(Unit: mm)

