

AVX, the world's leading manufacturer of Tantalum capacitors, has now released the world first Niobium Oxide Capacitors. AVX Niobium Oxide Capacitors are drawing worldwide attention because of their non-burn technology and availability and stability of raw materials supply. AVX is committed to total customer satisfaction by delivering products of the highest quality, providing strong technical support, and at competitive prices. With one of the fullest lineups in the capacitor business, AVX can satisfy a broad range of customer needs in a myriad of applications.

Tantalum Series Guide

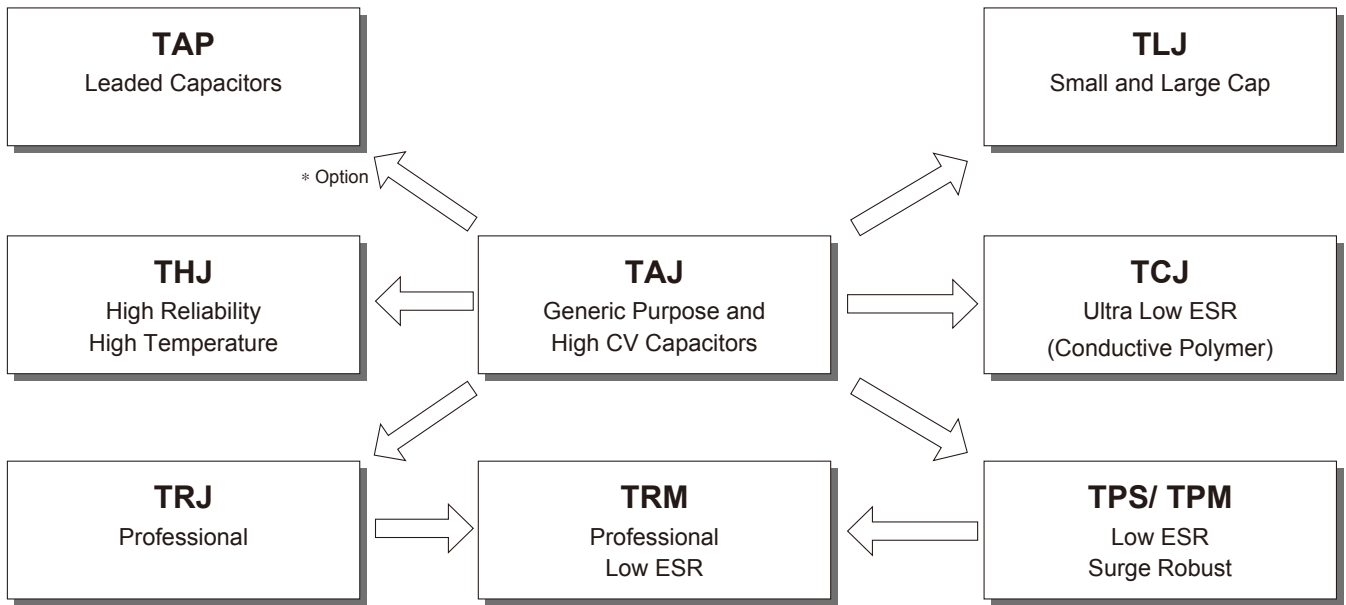

Niobium Oxide Series Guide

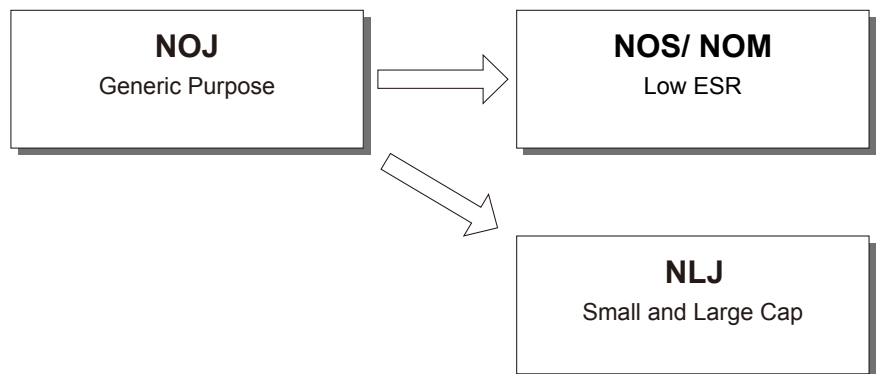

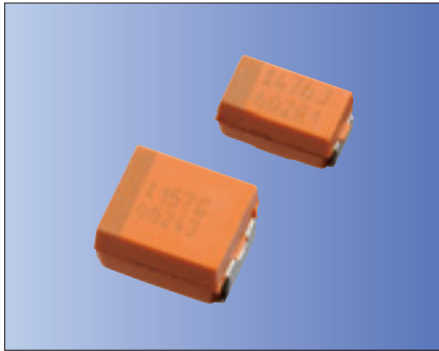

RoHS Compliant

Features

- Small and large cap

Applications

- Consumer applications

How to Order

NLJ B 157 M 004 R 1500
 ① ② ③ ④ ⑤ ⑥ ⑦

- ① Series
- ② Case Size (See Table)
- ③ Capacitance (pF)
(Code: 2 Significant Digits and Number of Zeros)
- ④ Tolerance

M	±20%
----------	------

- ⑤ Rated DC Voltage

ex.	006	6.3VDC
004	4VDC	016
		16VDC

- ⑥ Packaging

R	Plastic Tape (7" Reel)
----------	------------------------

- ⑦ ESR

ex.	1500	1500mΩ
------------	-------------	--------

Case Dimensions

(Unit: mm)

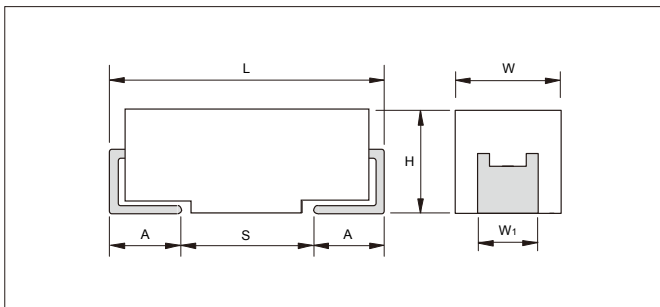

Case size	L	W	H	W ₁	A	S min.
A	3.2 ^{+0.2} _{-0.1}	1.6 ^{+0.2} _{-0.1}	1.6 ^{+0.2} _{-0.1}	1.2 ^{+0.2}	0.8 ^{+0.3} _{-0.2}	1.1
B	3.5 ^{+0.2}	2.8 ^{+0.2} _{-0.1}	1.9 ^{+0.2} _{-0.1}	2.2 ^{+0.2}	0.8 ^{+0.3} _{-0.2}	1.4
G	3.2 ^{+0.2}	1.6 ^{+0.2} _{-0.1}	1.5 max.	1.2 ^{+0.2}	0.8 ^{+0.3} _{-0.2}	1.1
P	2.05 ^{+0.2}	1.35 ^{+0.2} _{-0.1}	1.5 max.	1.0 ^{+0.1}	0.5 ^{+0.3} _{-0.2}	0.85
S	3.2 ^{+0.2}	1.6 ^{+0.2} _{-0.1}	1.2 max.	1.2 ^{+0.2}	0.8 ^{+0.3} _{-0.2}	1.1
T	3.5 ^{+0.2}	2.8 ^{+0.2} _{-0.1}	1.2 max.	2.2 ^{+0.2}	0.8 ^{+0.3} _{-0.2}	1.4

Specifications

Rated Voltage (V _R) ≤+ 40°C	4	6.3	10
Category Voltage (V _C) ≤+ 85°C	2	3.2	5
Category Voltage (V _C) ≤+105°C	1.3	2.1	3.3
Operating Temperature Range	-55°C to +105°C		
Failure Rate	0.2%/ 1000H (85°C, 0.5X Rated Voltage, 0.1Ω/V)		

Voltage Derating Curve

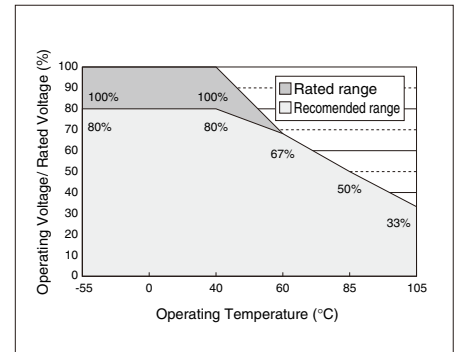

Capacitance and Voltage Range

Capacitance		Capacitance Range (letter denotes case code)		
μF	CODE	Rated Voltage		
		4V	6.3V	10V
10	106			
15	156			
22	226	P (4000)	S (1800)	
33	336		G (2200)	A (1700)
47	476		A (1600)/ T (1600)	B (1000)
68	686			
100	107		B (1700)	
150	157	B (1500)		

Note: Voltage ratings are minimum values. AVX reserves the right to supply higher voltage ratings in the same case size, to the same reliability standards.

Packaging

Tape and reel packaging for automatic component placement.
Please enter required suffix code, R or S on order.

• Reel

(Unit: mm)

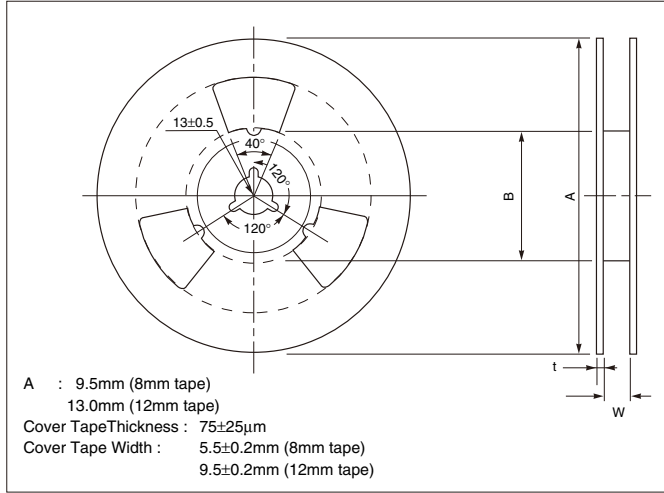

Reel Size	Tape width (mm)	A	B	C	W	t
180mm (7")	12	180±2.00	50 min.	13.0±0.50	12.4+1.5/-0	2.0±0.50
180mm (7")	8	180±2.00	50 min.	13.0±0.50	8.4+1.5/-0	2.0±0.50

• Taping

Series	Case Size	Tape Width (mm)	P (mm)	7" Reel (pcs.)
TAJ TPS TPM TCJ TLJ TRJ THJ TRM NOJ NOS NOM NLJ	A	8	4	2000
	B	8	4	2000
	C	12	8	500
	D	12	8	500
	E	12	8	400
	F	12	8	1000
	G	8	4	2500
	H	8	4	2500
	J	8	4	4000
	K	8	4	3000
	N	8	4	3000
	P	8	4	2500
	R	8	4	2500
	S	8	4	2500
	T	8	4	2500
	V	12	8	400
	W	12	8	1000
	X	12	8	1000
	Y	12	8	1000

• Carrier Tape

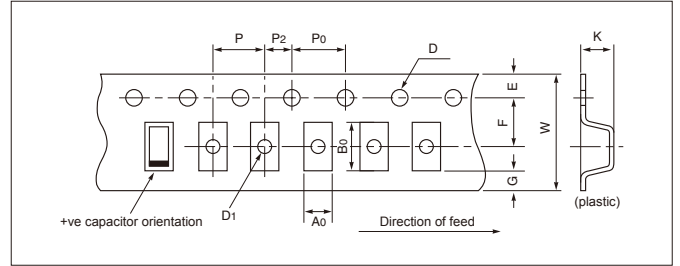

Tape dimensions comply to EIA 481 A.
Dimensions A0 and B0 of the pocket and the tape thickness, K, are dependent on the components size.
Tape material do not affect component solderability during storage.
Carrier tape thickness < 0.4mm

(Unit: mm)

Code	8mm tape	12mm tape
P	4±0.1	8±0.1
G	0.75 min.	0.75 min.
F	3.5±0.05	5.5±0.05
E	1.75±0.1	1.75±0.1
W	8±0.3	12±0.3
P ₂	2±0.05	2±0.05
P ₀	4±0.1	4±0.1
D	1.5 ^{+0.2} / _{-0.0}	1.5 ^{+0.2} / _{-0.0}
D ₁	1.0 min.	1.5 min.

• Carrier Tape

(Unit: mm)

Series	Case Size	A0	B0	K
TAJ TPS TPM TCJ TLJ TRJ THJ TRM NOJ NOS NOM NLJ	A	1.83±0.1	3.57±0.1	1.87±0.1
	B	3.15±0.1	3.77±0.1	2.22±0.1
	C	3.45±0.1	6.4±0.1	2.92±0.1
	D	4.48±0.1	7.62±0.1	3.22±0.1
	E	4.5±0.1	7.5±0.1	4.5±0.1
	F	3.35±0.1	6.4±0.1	2.2±0.1
	G	1.83±0.1	3.57±0.1	1.65±0.1
	H	3.15±0.1	3.77±0.1	1.66±0.1
	J	1.0±0.05	1.8±0.05	1.0±0.05
	K	1.95±0.1	3.55±0.1	1.15±0.1
	N	1.60±0.1	2.30±0.1	1.10±0.1
	P	1.65±0.1	2.45±0.1	1.6±0.1
	R	1.65±0.1	2.45±0.1	1.3±0.1
	S	1.95±0.1	3.55±0.1	1.3±0.1
	T	3.2±0.1	3.8±0.1	1.3±0.1
	V	6.43±0.1	7.44±0.1	3.84±0.1
	W	3.57±0.1	6.4±0.1	1.65±0.1
	X	4.67±0.1	7.62±0.1	1.65±0.1
	Y	4.67±0.1	7.62±0.1	2.15±0.1

Recommended Land Pattern

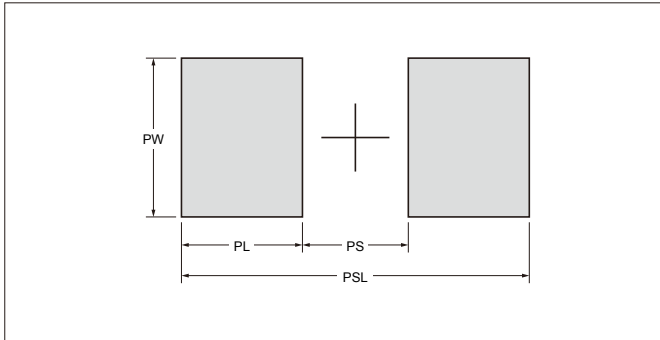

(Unit: mm)

Series	Case Size	PSL	PL	PS	PW
TAJ TPS TPM TCJ TLJ TRJ THJ TRM NOJ NOS NOM NLJ	A	4.00	1.40	1.20	1.80
	B	4.00	1.40	1.20	2.80
	C	6.50	2.00	2.50	2.80
	D	8.00	2.00	4.00	3.00
	E	8.00	2.00	4.00	3.00
	F	6.50	2.00	2.50	2.80
	G	4.00	1.40	1.20	1.80
	H	4.00	1.40	1.20	2.80
	J	2.80	1.10	0.60	1.00
	K	4.00	1.40	1.20	1.80
	N	2.70	0.95	0.80	1.60
	P	2.70	0.95	0.80	1.60
	R	2.70	0.95	0.80	1.60
	S	4.00	1.40	1.20	1.80
	T	4.00	1.40	1.20	2.80
	V	8.00	2.00	4.00	3.70
W	6.50	2.00	2.50	2.80	
X	8.00	2.00	4.00	3.00	
Y	8.00	2.00	4.00	3.00	

Recommended Reflow Profile for Lead-Free Product

Allowable range of peak temp./ time combination for IR reflow

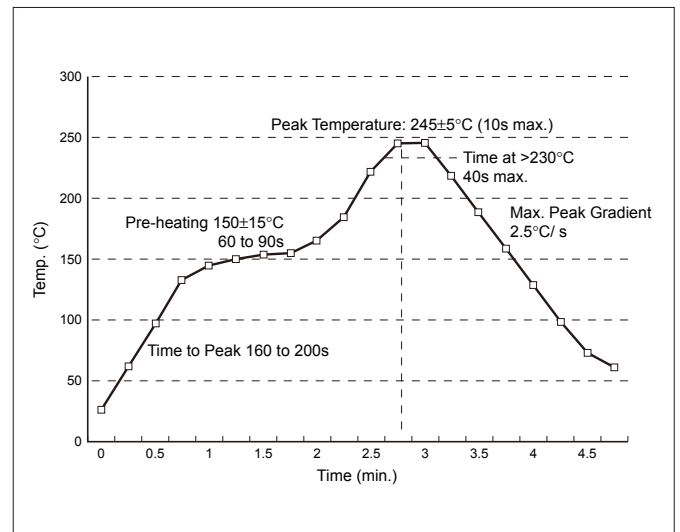

Please contact us for Lead-Free Products.

Manual Soldering Using Soldering Iron

Item	Condition
Max. Tip Temperature	370°C max.
Max. Exposure Time	3 sec. max.

Technical Summary

- Voltage Derating**
We can offer to use AVX software "Select-a-Cap" to select a part number for safety use.
- Surge Current**
As a general rule of thumb, the maximum current a tantalum capacitor can withstand is given by the following equation.

$$I_{max} = V_{rated} / (0.65 + \text{Catalog ESR})$$
 So for example for D case/ 100uF/ 10V capacitor (Catalog ESR = 0.9 Ohms)
 This would be :

$$I_{max} = 10 / (0.65 + 0.9) \doteq 6.45\text{Amps}$$
- If more aggressive mounting techniques are to be used, please contact AVX Tantalum for guidance.
- Reverse Voltage**
The values quoted are not intended to cover continuous reverse operation. The peak reverse voltage applied to the capacitor must not exceed.
 - 10% of rated DC voltage to a maximum of 1V at 25°C.
 - 3% of rated DC voltage to a maximum of 0.5V at 85°C.
 - 1% of category DC voltage to a maximum of 0.1V at 125°C.