

Crystal Units

Surface Mount Ledged Type CX49LFWA (CX-49L)



for Automotive



RoHS Compliant

Features

- Crystal unit for automotive electronics
- Metal package, leaded type
- A resistance weld hermetic sealed type
- Suitable for high density assembly and mass production
- AEC-Q200 certified

Applications

- ECU

How to Order

CX49LFWA 03200

- ① Series ② Frequency
 ③ Load Capacitance ④ Frequency Stability
- | | | | | | |
|-----------|-------|------|----------|--------------------------|------|
| DO | 8 pF | — | P | $\pm 50 \times 10^{-6}$ | — |
| HO | 12 pF | Std. | Q | $\pm 100 \times 10^{-6}$ | Std. |
- ⑤ Operating Temp. Range ⑥ Frequency Temp. Stability
- | | | | |
|-----------|---------------|--------------------------|------|
| SW | -40 to +125°C | $\pm 200 \times 10^{-6}$ | Std. |
|-----------|---------------|--------------------------|------|
- ⑦ Individual Specification

Specifications

Item	Symbol	Specification	Units	Remarks
Frequency Range	f _{nom}	3200 to 20000	kHz	
Overtone Order	OT	Fundamental	—	
Load Capacitance	CL	12	pF	
Frequency Stability	f _{tol}	± 100	$\times 10^{-6}$	25°C $\pm 3^\circ\text{C}$
Motional Series Resistance	R1	Table 1	ohm	
Drive Level	DL	Table 2	μW	
Operating Temp. Range	T _{use}	-40 to +125	°C	
Storage Temp. Range	T _{stg}	-40 to +125	°C	
Frequency Temp. Characteristics	f _{tem}	± 200	$\times 10^{-6}$	Freq. deviation from the value at 25°C

* Please contact us for other specifications.

Typical Frequencies and Part Numbers

Frequency (kHz)	Part Number
4000.000	CX49LFWA04000H0QSWZ1
5000.000	CX49LFWA05000H0QSWZ1
6000.000	CX49LFWA06000H0QSWZ1
8000.000	CX49LFWA08000H0QSWZ1
10000.000	CX49LFWA10000H0QSWZ1
12000.000	CX49LFWA12000H0QSWZ1
16000.000	CX49LFWA16000H0QSWZ1
18000.000	CX49LFWA18000H0QSWZ1
20000.000	CX49LFWA20000H0QSWZ1

Table1 Motional Series Resistance

Frequency Range	Motional Series Resistance
3200 to 3499kHz	300Ω max.
3500 to 4099kHz	150Ω max.
4100 to 4799kHz	120Ω max.
4800 to 5999kHz	100Ω max.
6000 to 11999kHz	90Ω max.
12000 to 13499kHz	70Ω max.
13500 to 20000kHz	50Ω max.

Table2 Level of Drive

Frequency Range	Level of Drive
3200 to 15999kHz	10μW (500μW max.)
16000 to 20000kHz	10μW (300μW max.)

Dimensions

(Unit: mm)

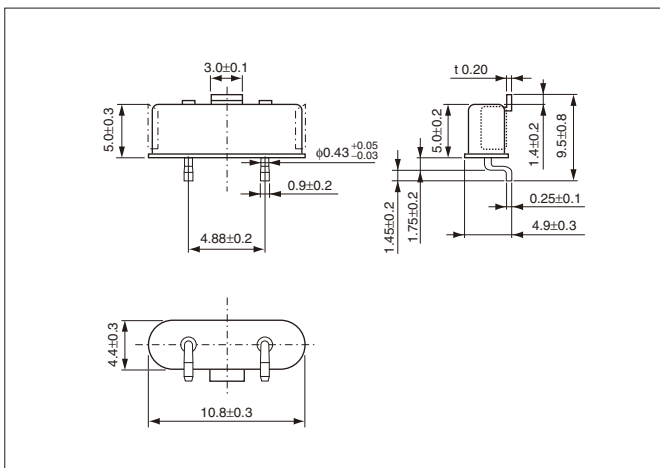

Recommended Land Pattern

(Unit: mm)

